

# Cree® XLamp® 7090 XR-E Series LED Secondary Optics

Cree XLamp LEDs combine the brightness of power LED chips with a robust package capable of operating from half of a watt to in excess of two watts. Cree XLamp LEDs lead the solid-state lighting industry in brightness while providing a reflow-solderable design that is optimized for ease of use and thermal management. Lighting applications featuring XLamp LEDs maximize light output and increase design flexibility while minimizing environmental impact.

The XLamp LED family brings the power of brightness to a wide range of lighting and backlighting applications, including portable lighting and flashlights, computer and television screens, signaling, architectural, landscaping, and entertainment.

## FEATURES

- Specifically designed for Cree's XLamp 7090 XR-E Series LED package
- High light-collection efficiency of > 90%
- Uniform CCT across the beam
- Precision-molded in optical grade PMMA (acrylic)
- Fits easily with holder



XLamp 7090 XR-E Series LEDs provide an 75-degree viewing angle. Cree recognizes the need for different beam shapes and angles for specialized applications and is working with a number of optics designers and manufacturers to develop a line of secondary optics for use with its XLamp products. Initial efforts have resulted in the development of high-quality collimator secondary optics that efficiently collect and direct light from Cree XLamp 7090 XR-E Series LEDs using the industry-standard total internal reflection (TIR) technique. Details for the new optics are provided on the following pages. Cree is also working on designing additional collimators as well as reflectors that extend the options for beam and viewing-angle control.

Designs for the secondary optics are available from Cree at no charge to customers utilizing XLamp LEDs in their lighting applications. To obtain a free copy of these designs or to obtain more information on where to purchase these optics, please contact your XLamp LED sales representative. In addition, Cree is working with several third-party suppliers to make these secondary optics available for purchase by Cree XLamp LED customers on a standardized part-number basis.

## Characteristics

Part Number	Typical Beam Full Width Half Maximum (°)
	White
XLSL-7090-247	8

## Mechanical Dimensions and Assembly

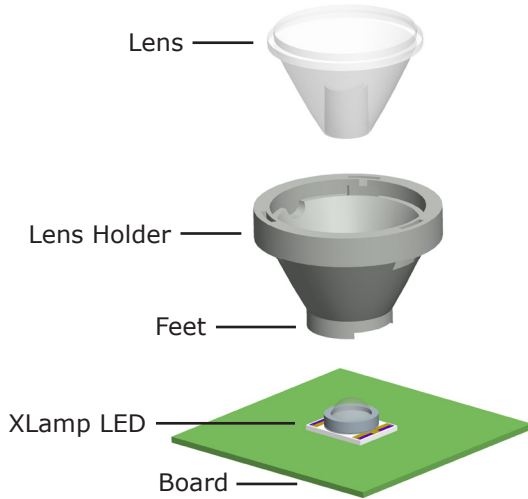

To assemble the lens with the holder:

1. Align the lens with the holder and press-fit the lens into place.
2. Align the holder with the LED and glue the feet onto the circuit board.\*
3. LEDs must be handled with care to avoid damage to the lens. For more information, see Cree's application note "Cree XLamp LED Soldering and Handling."

\* Cree recommends using a high-strength adhesive such as 3M™ Scotch-Weld™ Epoxy Adhesive DP190.

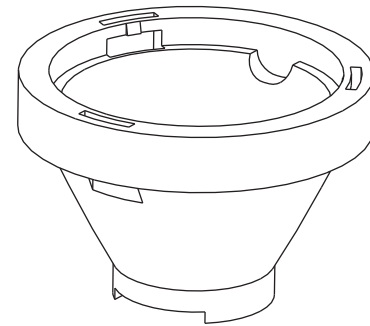

Top View - lens holder for Lens 247

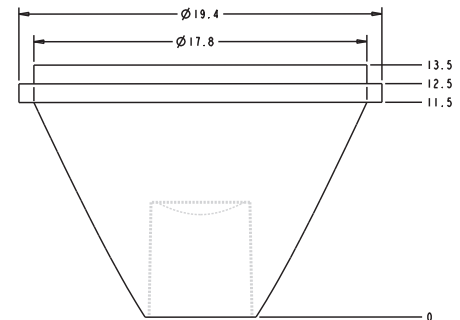

Mechanical Dimensions - Lens 247  
(dimensions in mm.)

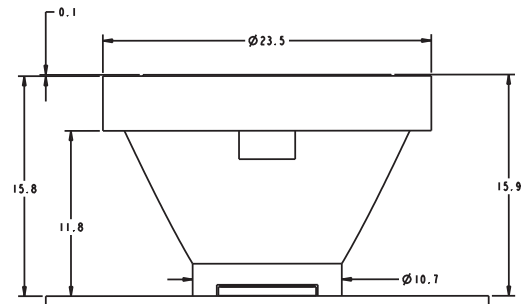

Mechanical Dimensions - lens holder  
with Lens 247 (dimensions in mm.)

**XLSL-7090-247**

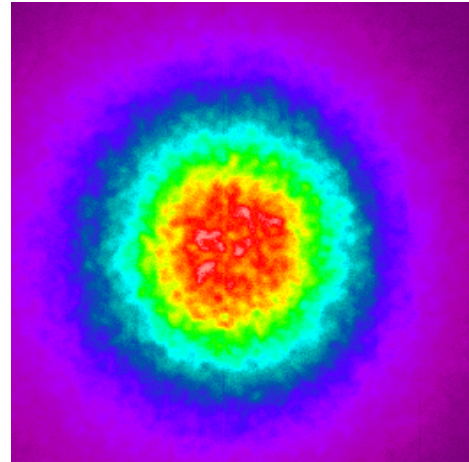
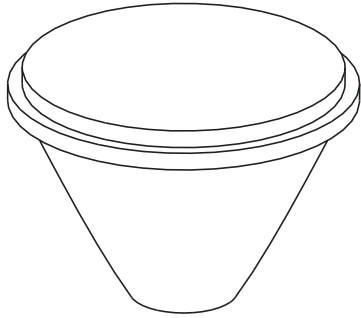

**Lens 247 - Angular Intensity Distribution**

Beam Pattern

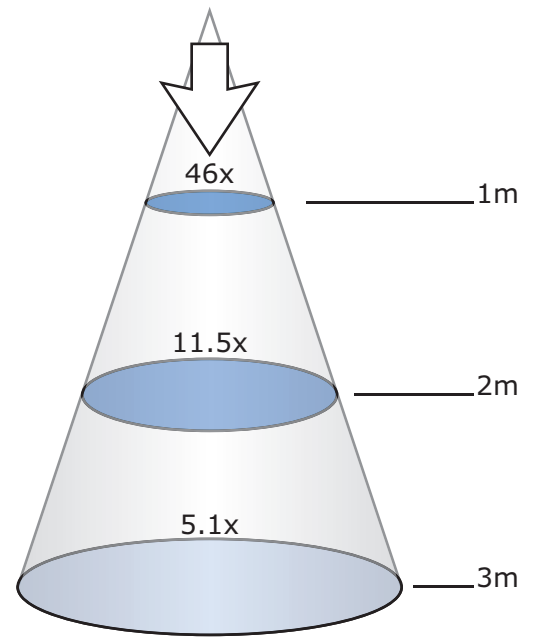
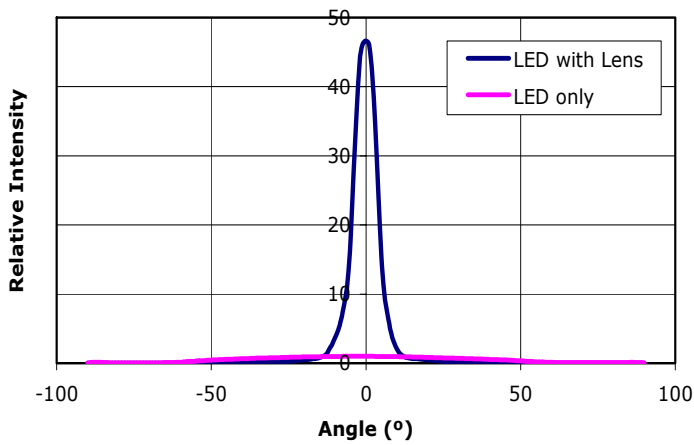

Illuminance chart white LED with Lens 247

X is the illuminance of a white LED without secondary optics at a distance of one meter.